



LXT-010S-H SFP+ GPON ONT Stick

1244Mbps TX 2488Mbps RX With GPON MAC

The LXT-010S-H SFP GPON ONU stick module has been designed for FTTx applications.

LXT-010S-H is an GPON ONT device, based on state-of-art Hisense LTE3415 hardware, and LeoLabs.pl software providing best in class wide interoperability with various OLT vendors.

Main SoC used in LXT-010S-H is best in class Realtek RTL9601C.



Passive Optical Network (PON) technology offers some competitive advantages, including a long-term life expectancy of the fiber infrastructure, lower operating costs through the reduction of “active” components, greater distance support between equipment nodes, and most importantly, much greater bandwidth. Well satisfying the high speed access demand, GPON has a more prosperous perspective.

LXT-010S-H provides the core functionality of an ITU-T G984.5 GPON Optical Network Terminal (ONT) . In addition, the device also offers some advanced functions such as DBA,AES, FEC, PLOAM,OMCI. A powerful Network Processor is provided to allow for traffic prioritization, local address filtering, and statistics gathering. A dedicated processor provides management control and responds to in-band OAM commands and Host Interface messages for configuration and statistics gathering. By means of configuring personal variables accordingly, the customer can get a device that will fit various application very well.

Applications

- Home Gateway
- Network switch, router and MDU

Features

- Single fiber Bi-directional with 2488Mb/s Downstream.
- Single fiber Bi-directional with 1244Mb/s Upstream
- 1310nm DFB Burst Mode Laser
- 1490nm CW Mode Receiver
- Optical link measurement and diagnosis
- Downstream AES decryption
- Highly flexible 802.1Q VLAN support
- Single 3.3V DC supply
- SFP Package Outline
- Single Fiber, Full Duplex Operation
- SC/UPC Optical Connector
- 2X10 Electrical SFP Connector
- Operating Temperature Range:
Industrial : -40 to 85 °C
- Power Consumption < 2w
- RoHs Compliance
- Supporting 1000BASE-X/2500BASE-X/SGMII/HSGMII interface



LXT-010S-H SFP+ GPON ONT Stick

1244Mbps TX 2488Mbps RX With GPON MAC

Absolute Maximum Ratings					
Parameter	Symbol	Min	Max	Units	Notes
Storage Ambient Temperature	T_{stg}	-40	+85	°C	Exceeding the Absolute Maximum Ratings may cause irreversible damage to the device. The device is not intended to be operated under the condition of simultaneous Absolute Maximum Ratings, a condition which may cause irreversible damage to the device.
Relative Humidity - Storage	RH_S	0	95	%	
Relative Humidity - Operating	RH_O	5	80	%	
Module Supply Voltage	V_{CC}	GND	3.6	V	
Tx_DIS Logic HIGH State	Tx_DIS_H	2.0	V_{CC}	V	LVTTTL
Tx_DIS Logic LOW State	Tx_DIS_L	0	0.8	V	
Tx_FAULT Logic HIGH State	Tx_Fault_H	2.4	-	V	LVTTTL (Open Collector/Drain)
Tx_FAULT Logic LOW State	Tx_Fault_L	-	0.4	V	
Rx_LOS Logic HIGH State	Rx_LOS_H	2.4	-	V	LVTTTL (Open Collector/Drain)
Rx_LOS Logic LOW State	Rx_LOS_L	-	0.4	V	

Recommended Operating Conditions						
Parameter	Symbol	Min	Typ	Max	Units	Notes
Operating Case Temperature	T_{CASE}	-40	25	85	°C	Temperature = I
Module Supply Voltage	V_{CC}	3.135	3.3	3.465	V	
Module Supply Current (Tx and Rx)	I_{IN}	-	550	-	mA	
Module Power Consumption	P_D	-	-	2	W	
Optical upstream Data Rate	BR	-	1244	-	Mbps	
Optical downstream Data Rate	BR	-	2488	-	Mbps	



LXT-010S-H SFP+ GPON ONT Stick

1244Mbps TX 2488Mbps RX With GPON MAC

Transmitter Electrical Characteristics						
Parameter	Symbol	Min	Typ	Max	Unit	Conditions / Notes
Tx_Data Differential Input Voltage	V_{ID}	300	-	1200	mV	SGMII mode
Bit Rate(TX)	BR_{TX}	-	1250	-	Mbps	SGMII mode
Tx_DIS = HIGH (Transmitter OFF)	V_{OH}	2.0	-	V_{CC}	V	
Tx_DIS = LOW (Transmitter ON)	V_{OL}	0	-	0.8	V	

Receiver Electrical Characteristics						
Parameter	Symbol	Min	Typ	Max	Unit	Conditions / Notes
Rx_Data Differential Output Voltage	V_{OD}	300	-	800	mV	1250Mbps
Rx_Data Differential Output Voltage	V_{OD}	500	-	1000	mV	2500Mbps
Rx_LOS Logic HIGH State	$V_{LOS,H}$	2.4	-	-	V	LVTTTL(Open Collector/Drain)
Rx_LOS Logic LOW State	$V_{LOS,L}$	-	-	0.8	V	

Transmitter Optical Characteristics						
Parameter	Symbol	Min	Typ	Max	Units	Conditions / Notes
Transmitter Type		1310 nm DFB Burst Mode				
Upstream Signaling Speed	Sup	-	1244	-	Mb/s	
Average Output Power (9/125 μ m SMF)	P_{out}	0	-	5.0	dBm	Note 1
Optical Output with Tx OFF	P_{out}	-	-	-40	dBm	
Tx Wavelength	λ	1290	1310	1330	nm	
Spectral Line Width @-20dB	$\Delta\lambda$	-	-	1.0	nm	
Extinction Ratio	ER	10	-	-	dB	Measured by Ethernet package with random payload.
Side Mode Suppression Ratio	SMSR	30	-	-	dB	

Receiver Optical Characteristics						
Parameter	Symbol	Min	Typ	Max	Units	Conditions / Notes
Receiver Type		1490nm CW Mode				
Downstream Signaling Speed	Sdown	-	2488	-	Mb/s	
Optical Center Wavelength	λ	1480	1490	1500	nm	
Receiver Sensitivity	P_{IN}	-	-	-28.0	dBm	BER<10 ⁻¹⁰ , 2488 Mb/s, PRBS 2 ²³ -1, ER=11dB
Receiver Optical Overload	$P_{IN}(SAT)$	-8	-	-	dBm	
Rx_LOS of Signal Asserted	P_A	-45	-	-	dBm	
Rx_LOS of Signal Deasserted	P_D	-	-	-28.5	dBm	
Rx_LOS of Signal Hysteresis	P_{Hy}	0.5	-	6.0	dB	

Note 1: Measured with 9/125 μ m G.652 SMF.



LXT-010S-H SFP+ GPON ONT Stick

1244Mbps TX 2488Mbps RX With GPON MAC

LXT-010S-H Block Diagram

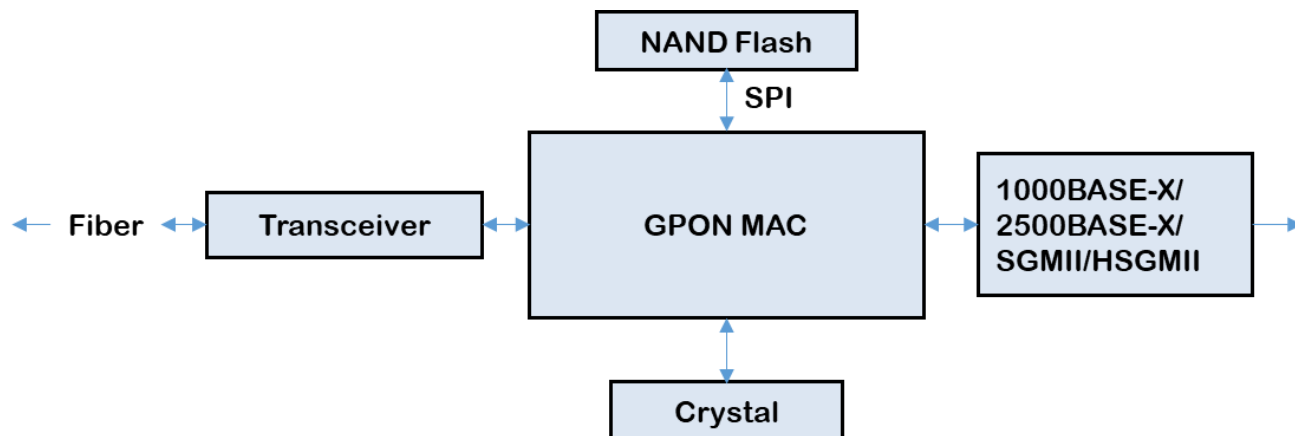



LXT-010S-H SFP+ GPON ONT Stick

1244Mbps TX 2488Mbps RX With GPON MAC

Memory Map(Page 0xA0 HEX, Unlisted Fields are Blank/Empty, Memory is WRITE PROTECTED, SDA Communications is READ ONLY)				
IIC Addr	Size	Name	Description	Values (HEX)
0	1	Identifier	SFP transceiver	03
1	1	Extended Identifier	MOD4	04
2	1	Connector	SC	01
3-10	8	Transceiver	1000Base-L	00 00 00 02 00 00 00 00
11	1	Encoding	Encoding Type = NRZ	03
12	1	BR, Nominal	Nominal Bit Rate 1244 Mb/s	0D
13	1	Reserved	Reserved	00
14	1	Length(9µm)-km	20km Link Length in Kilometers / SMF	14
15	1	Length (9µm)-100m	20km Link Length in Hundreds of Meters / SMF	C8
16	1	Length (50µm)-10m	50-micron MMF Link Length = N/A	00
17	1	Length (62.5µm)-10m	62.5-micron MMF Link Length = N/A	00
18	1	Length (Copper)	Copper Link Length = N/A	00
19	1	Reserved	Reserved	00
20-35	16	Vendor name	Hisense	ASCII Format
36	1	Reserved	Reserved	00
37-39	3	Vendor OUI	SFP Vendor IEEE Company ID	AC 4A FE
40-55	16	Vendor PN	The Part Number in the ordering information	ASCII Format
56-59	4	Vendor Revision Number	Programmed by Factory	Programmed by Factory
60-61	2	Wavelength	Laser Wavelength = 1310nm	05 1E
62	1	Reserved	Reserved	00
64-65	2	Transceiver Options	65.1:Rx_LOS 65.3:Tx_FAULT 65.4:Tx_DISABLE	00 1A
66	1	BR, max	00	00
67	1	BR, min	00	00
68-83	16	Vendor SN	Serial number provided by vendor	Programmed by Factory
84-91	8	Date code	Vendor's manufacturing date code	Programmed by Factory
92	1	Monitoring Type	Monitoring Implemented Address Change Required	68
93	1	Enhanced Options	95.7:Optional Alarm/Warning Flags Implemented 95.6:Soft Tx_DISABLE Monitor and Implemented 95.4:Soft Rx_LOS Monitor 95.5:Soft Tx_FAULT Monitor	F0
94	1	Compliance	Revision Implemented	08
95	1	CC_EXT	Check_Sum (64 to 94)	Programmed by Factory
96-127	32	Vendor Specific	Vendor Specific EEPROM	Programmed by Factory
128-255	128	Vendor Specific	Vendor Specific EEPROM	Programmed by Factory



LXT-010S-H SFP+ GPON ONT Stick

1244Mbps TX 2488Mbps RX With GPON MAC

PIN Assignment

TOP VIEW
OF BOARD

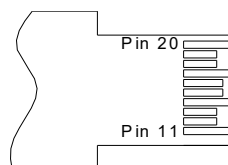

BOTTOM VIEW
OF BOARD

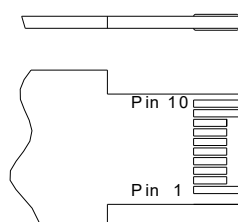

PIN Assignment			
Pin	Symbol	Description	Notes
1	V _{EET}	Transmitter Ground	
2	Tx_FAULT	Transmitter Fault, LOW = Normal Operation, HIGH = Fault Indication	1
3	Tx_DIS	Transmit Disable, LOW = Normal Operation, HIGH = Disables Module	1
4	MOD_DEF 2	Module Definition 2 - Two-Wire Interface - Serial Data	1
5	MOD_DEF 1	Module Definition 1 - Two-Wire Interface - Clock Signal	1
6	MOD_DEF 0	Module Definition 0 - Presence Pin, the MOD_DEF0 Signal set to low level after initialisation of μ C and power up the I2C interface	
7	Dying Gasp	Dying Gasp Indication, when high indicates normal operation, low indicates power fail	4
8	LOS	Loss of Signal, When high indicates no optical power; Low indicates normal operation	1
9	PIN9	Reserved. Keep floating when unused.	
10	V _{EER}	Receiver Ground	
11	V _{EER}	Receiver Ground	
12	RD-	Rx_Data Output (Inverted)	2
13	RD+	Rx_Data Output (Non Inverted)	2
14	V _{EER}	Receiver Ground	
15	V _{CCR}	Receiver DC Power	3.3 V +/- 5%
16	V _{CCT}	Transmitter DC Power	3.3 V +/- 5%
17	V _{EET}	Transmitter Ground	
18	TD+	Tx_Data Input (Non Inverted)	3
19	TD-	Tx_Data Input (Inverted)	3
20	V _{EET}	Transmitter Ground	
Notes			
<ol style="list-style-type: none"> The uncommitted Tx_FAULT, Tx_DIS, MOD_DEF2, MOD_DEF1 and LOS monitor and control pins each require a pull up resistor of 4.7k to 10k Ohms. The pull-up voltage must be 3.3V. The 100Ohms differential Rx Data output is internally AC coupled. Supporting 1000BASE-X/2500BASE-X/SGMII/HSGMII interface The 100Ohms differential Tx Data input is internally AC coupled. Supporting 1000BASE-X/2500BASE-X/SGMII/HSGMII interface Voltage Detect Input for Dying Gasp. When the voltage on this pin is lower than 1.29V +/- 5%, a dying gasp event is triggered. A 4.7k Ohm resistor is used to pull up to DC Power in the module. 			



LXT-010S-H SFP+ GPON ONT Stick

1244Mbps TX 2488Mbps RX With GPON MAC

LXT-010S-H Electrical Interface

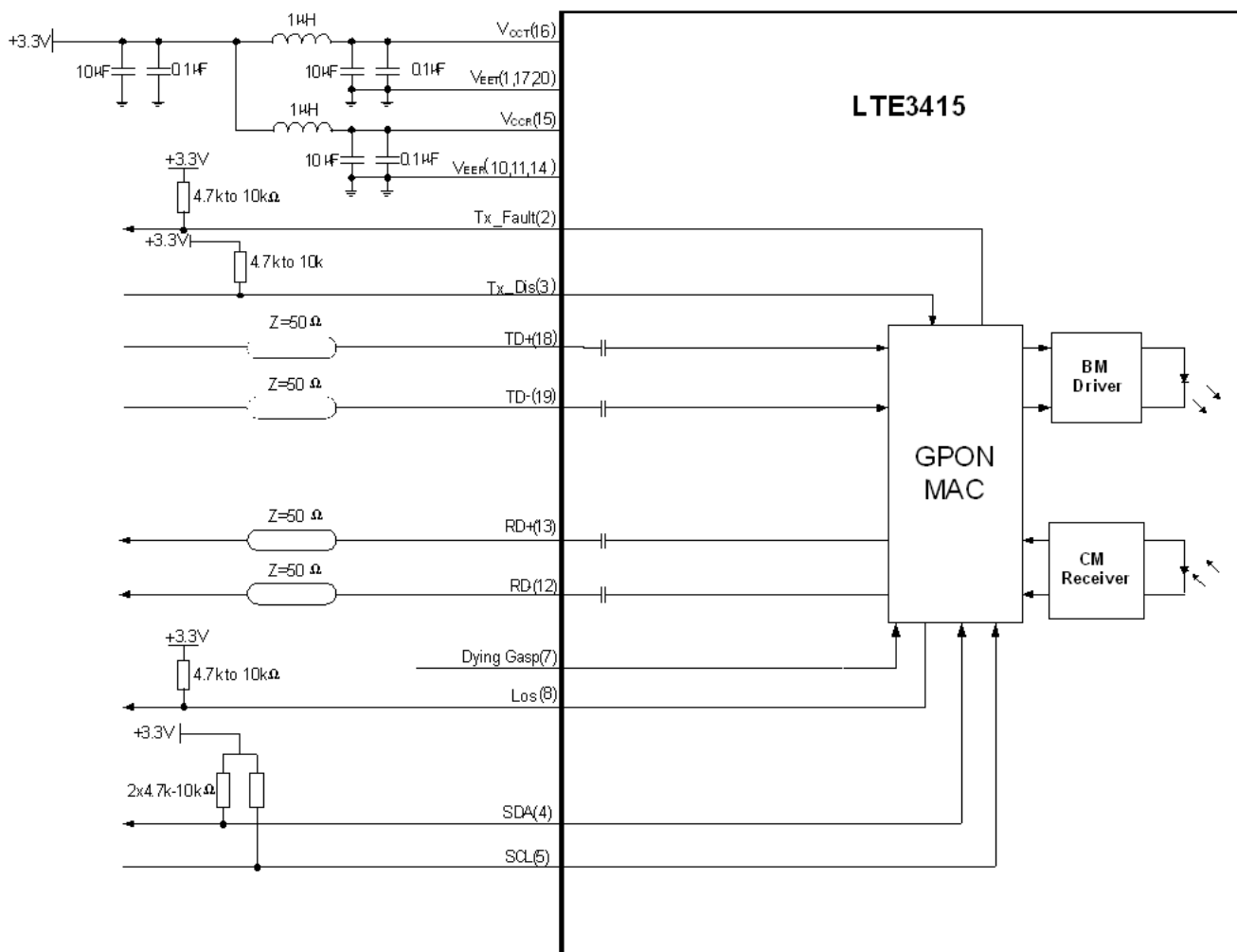



LXT-010S-H SFP+ GPON ONT Stick

1244Mbps TX 2488Mbps RX With GPON MAC

Recommended PCB Layout

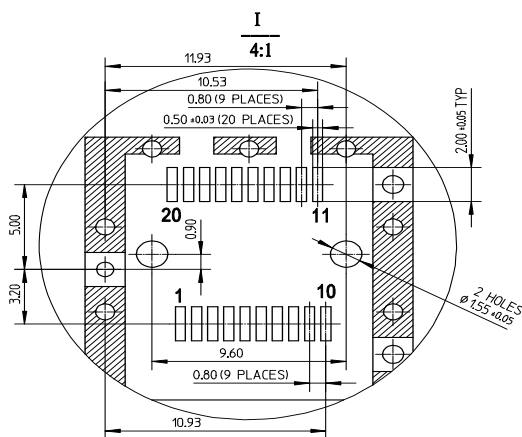

- Notes:**
1. Datum and basic dimensions established by customer
 2. Pads and vias are chassis ground, 11 places
 3. Thru holes, plating optional

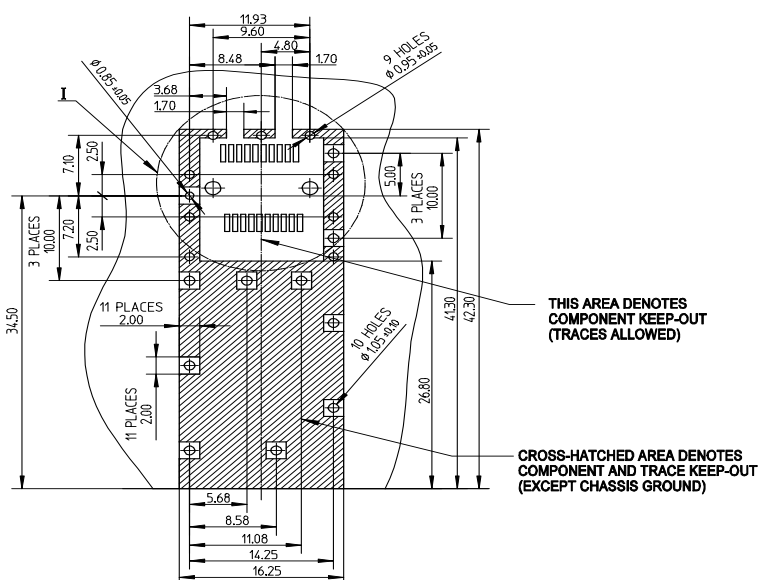

Recommended Front Panel Layout

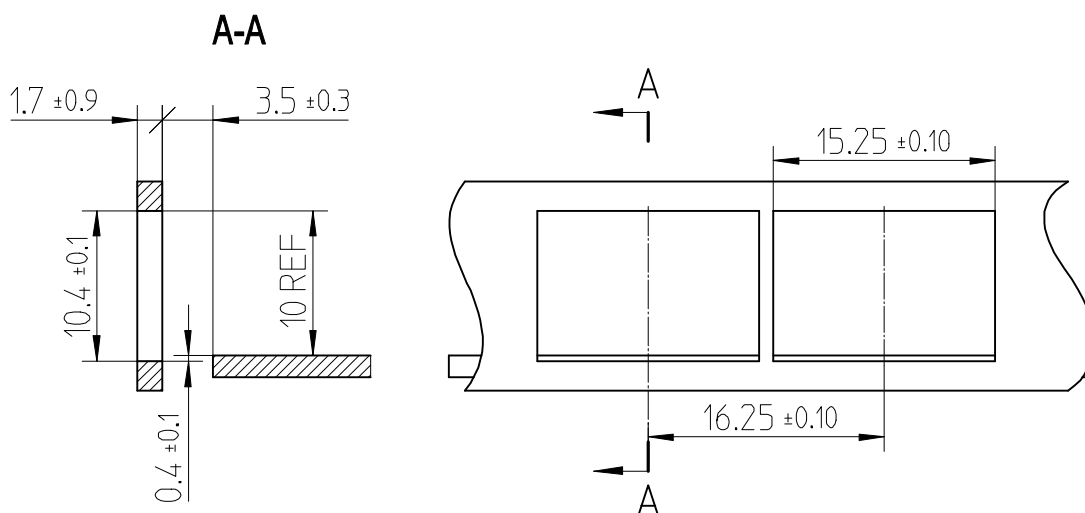



LXT-010S-H SFP+ GPON ONT Stick

1244Mbps TX 2488Mbps RX With GPON MAC

LXT-010S-H 2x10 SFP with SC RECEPTACLE OUTLINE DRAWING

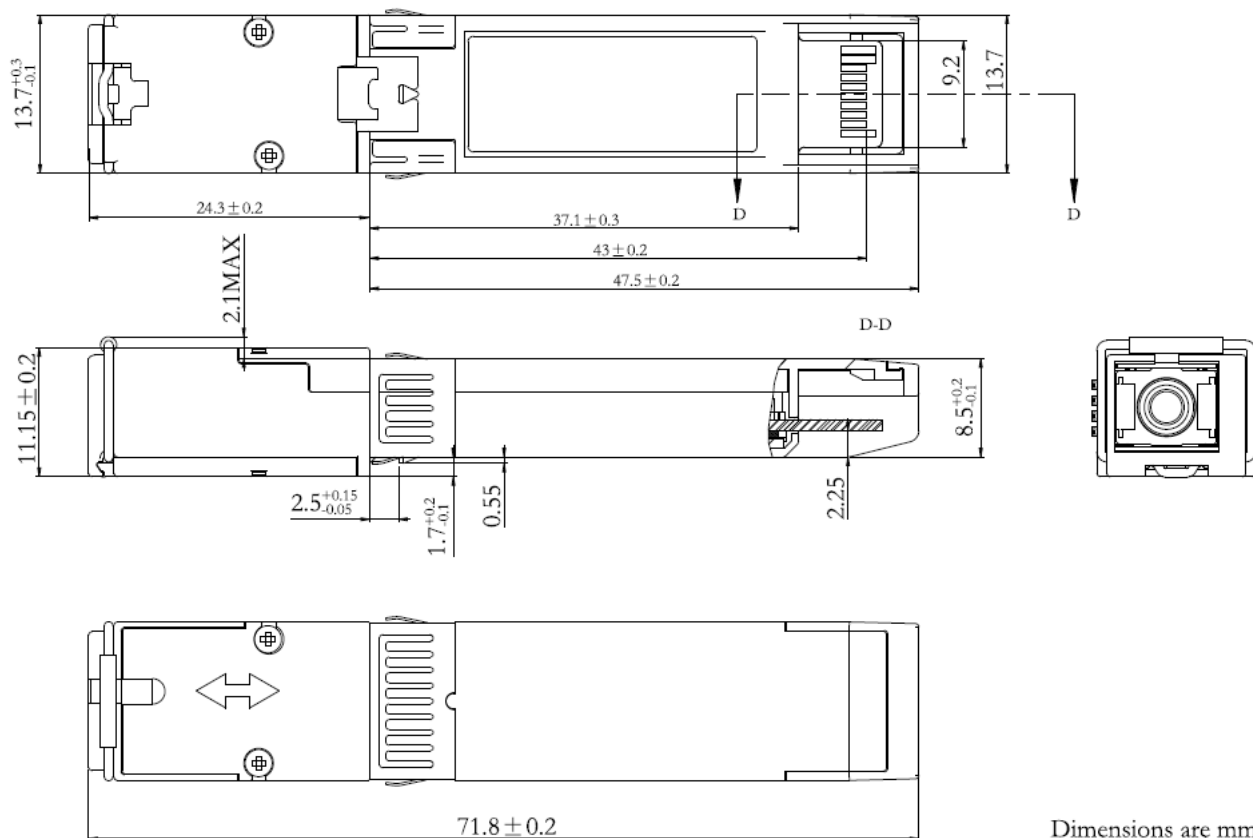

Dimensions are mm
Tolerance is ± 0.1 mm



LXT-010S-H SFP+ GPON ONT Stick

1244Mbps TX 2488Mbps RX With GPON MAC

Warnings

Handling Precautions:

This device is susceptible to damage as a result of electrostatic discharge (ESD). A static free environment is highly recommended. Follow guidelines according to proper ESD procedures.

Laser Safety:

Radiation emitted by laser devices can be dangerous to human eyes. Avoid eye exposure to direct or indirect radiation.

Global Sales Offices

LeoLabs sp. z o.o.

ul. Jankowicka 51

44-218 Rybnik, POLAND

General info: contact@leolabs.pl

Sales: sales@leolabs.pl

Support: support@leolabs.pl