

Network level 4: Secure indoor networks.

speed·pipe® indoor.

Laying instructions.

www.gabocom.com



CO

nt

ent

Publisher.

gabo Systemtechnik GmbH
a HellermannTyton Company
Am Schaidweg 7
94559 Niederwinkling
GERMANY

Tel. +49 9962 950-200
Fax +49 9962 950-202
info@gabocom.com
www.gabocom.com

Business division gabocom
Author: Alexandra Friedl
Approval: Markus Karl
Edition 9
May 2026

The current version of the laying instructions are available to download at www.gabocom.com.

After leaving gabo Systemtechnik GmbH this document is not subject to be changed. No responsibility is taken for the correctness, timeliness and completeness of details and information. This document can be revised and completed without prior notice. Liability for damages is excluded.

Pages 4 – 6	1	General
Pages 8 – 9	2	Utilisation of speed•pipe® indoor
Pages 10 – 17	3	Laying instructions speed•pipe® indoor
Pages 10 – 13	3.1	Installation principles for indoor areas
Pages 13 – 15	3.2	Installation according to DIN VDE 0100-520 / IEC 60364-5-52+A1:2024
Page 16	3.3	Bending radius
Page 17	3.4	Tensile forces
Page 15	3.5	Cutting speed•pipe® indoor
Pages 18	4	Firewall
Pages 19 – 23	5	Blowing in micro cables / mini cables / bundle fibres
Page 19	5.1	Dependence of the blowing in lengths to be achieved on several factors
Pages 20 – 21	5.2	Reference values for blowing in
Page 22	5.3	Optimum blowing in lengths
Page 23	5.4	Optimum blowing in
Page 23	5.5	Use of lubricant
Pages 24 – 27	6	Pictures from building site

Network level 4: Secure networks for internal infrastructure.

General information at the beginning. speed•pipe[®] indoor.

High-speed networks are a must for all new buildings and extensive renovations. Particularly inside buildings, strict material requirements are applied – especially with regard on fire protection.

The speed•pipe[®] indoor system masters the balance between safety, optimum blowing characteristics and ease of installation.

The contents in chapters 1 – 2:

- Overview of general information
- Field of application

These installation instructions are essential for the construction and assembly work in order to successfully guarantee the functionality of your network.



1. Overview.

Protection from contamination and mechanical damage.

The speed•pipe® indoor must be protected against contamination and mechanical damage during transport, storage and processing.

Avoid damage and distortion.

Any damage and deformation of the speed•pipe® indoor (e. g. ovalisation) must be avoided and cause a decrease in the blowing distance of the micro cables.

The speed•pipe® indoor ends must be protected against the penetration of dirt and water by means of dust covers, indoor end plugs ES or indoor sealing elements EZA-t.

Dust covers:	protection against dust, dirt and splashing water, not pressure-tight
Indoor end plugs:	pressure-tight up to 0.5 bar
Indoor sealing elements:	pressure-tight up to 0.5 bar

When storing them over a long period of time (several months) the speed•pipe® indoor must be protected against direct solar radiation. In principle avoid outdoor storage.

It is impossible to make a general statement about the functional integrity of the speed•pipe® indoor, because the dimension of the particular speed•pipe® indoor as well as the related cable must be individually checked in combination.

Please note:
The laying instructions are important for the correct completion of construction and installation work.

2. Utilisation of speed•pipe® indoor.

In course of broadband expansion the fibre is continuously moved closer towards the client.

FTTH (Fibre to the home) means that the fibre is laid into the apartment of apartment buildings or into single-family houses.

Furthermore the speed•pipe® indoor allows a smart home network cabling. In this case the installation in the building is a challenge due to a lack of infrastructure and to the fire protection requirements. Free spaces and shafts are usually very small so that's not possible to work with commercially available products.

The new speed•pipe® indoor system.

With the new speed•pipe® indoor system, the solutions for the different local conditions and requirements in the buildings can be designed and installed. The non-flame propagating, halogen-free and high-quality products are compliant with European directives.



Available speed•pipe® indoor dimensions.

Term	D x s (mm)	Length (m)	kg / m	Pressure	Spool D x s (mm)	G (kg)*	Item no.
speed•pipe® indoor 5 × 0.75	5 × 0,75	400	ca. 0,011	PN 16	340 × 340 × 340 (Karton)	ca. 8	3511
		1000	ca. 0,011	PN 16	600 × 360	ca. 17	3501
speed•pipe® indoor 7 × 1.5	7 × 1,5	250	ca. 0,030	PN 16	340 × 340 × 340 (Karton)	ca. 12	3513
		500	ca. 0,030	PN 16	600 × 360	ca. 21	3502
		1250	ca. 0,030	PN 16	700 × 370	ca. 51	3503
speed•pipe® indoor 10 × 1.0	10 × 1,0	500	ca. 0,030	PN 10	700 × 370	ca. 28	3504
		2500	ca. 0,030	PN 10	1200 × 370	ca. 103	3505
speed•pipe® indoor 10 × 2.0	10 × 2,0	2500	ca. 0,053	PN 16	1200 × 370	ca. 165	3525
speed•pipe® indoor 12 × 2.0	12 × 2,0	350	ca. 0,066	PN 16	700 × 370	ca. 36	3506
		2000	ca. 0,066	PN 16	1200 × 370	ca. 160	3507
speed•pipe® indoor 14 × 2.0	14 × 2,0	250	ca. 0,076	PN 16	700 × 370	ca. 32	3508
		1500	ca. 0,076	PN 16	1200 × 370	ca. 142	3509

→ **Additional dimensions on request**
G (kg)* = total weight including spool
Colour: white



Network level 4: Secure indoor networks.

Laying instructions. speed•pipe® indoor in practical use.

With speed•pipe® indoor every type of building is equipped for emergencies. The system meets all requirements in terms of its technical properties. According to the EU Low Voltage Directive 2014/35/EU the speed•pipe® indoor system entirely is tested in accordance with EN 61386-22.

In the following chapters 3 – 5 you will find all necessary steps for a practical application of the speed•pipe® indoor system:

- Installation and instructions
- Bending radius
- Tensile forces
- Cutting speed•pipe® indoor
- Firewalls
- Blowing in micro / mini cables and bundle fibres

Note:

Please note that the local conditions and specific laying procedures may lead to deviations from the recommended principles in chapters 3 – 5.

Laying instructions speed•pipe® indoor.

3.1 Installation principles for indoor areas.

- Direct installation of speed•pipe® indoor in the ground is not permitted!
- **Transition to speed•pipe® indoor after entering the building:**
In accordance with relevant standards (DIN 50174 – Installation of communication cabling), speed•pipe® indoor (non-flame-retardant according to DIN EN 61386) must be used within 2 meters after entering the building.
The cables to be used in the in-house area must be selected independently of speed•pipe® indoor in order to comply with the regulations specifically applicable to in-house cables.

3.2 Installation according to DIN VDE 0100-520 / IEC 60364-5-52+A1:2024.

All dimensions of speed•pipe® indoor were tested in the VDE test institute according to DIN EN 61386-22.

Here, the mechanical strength values are taken from the table F.52.1 under point 521.6 (DIN VDE 0100-520), which the electrical installation pipes (speed•pipe® indoor) must correspond to.

Essentially are the first four digits of the code, which reflect the following values by means of defined tests:

- Compressive strength of the electrical installation pipes
- Impact strength of the electrical installation pipes
- Minimum operating temperature of the electrical installation pipe (Classification code 2 -5 °C)
- Maximum operating temperature of the electrical installation pipes (Classification code 2 +90 °C)

Further tests of the electrical installation pipes:

Further tests of the electrical installation pipes (speed•pipe® indoor) are, for example, the resistance to bending, the tensile strength, the load capacity, the electrical properties, resistance to external influences and resistance to flame spread.

The mechanical strengths are classified from positions 1 – 4 (5), whereby 1 is the lowest classification – for example “very low” – and 4 (5) is the highest classification – for example „very high“.

The speed-pipe® indoor have the following classification code according to EN 61386-22 and thus the following use according to DIN VDE 0100-520 / IEC 60364-5-52+A1:2024:

Use of the speed-pipe® indoor
5 x 0.75 // 10 x 1.0:

Classification

Classification code
DIN EN 61386-22 (VDE 0605 Part 22) 2-2-2-2-3

Use according to DIN VDE 0100-520 / IEC 60364-5-52+A1:2024

Installation	Allowed	Not allowed
In the building		
Unprotected installation (on plaster)	x	
Underground installation (screed)		x
Laid in concrete		x
Laid in hollow wall / wood (flammable materials)	x	
Laid in plaster	x	
Laid in structural cavities	x	
Laid in suspended ceilings	x	
Ceiling installation (installation distance < 0.80 m)	x	

Use of the speed-pipe® indoor
7 x 1.5 // 10 x 2.0 // 12 x 2.0 // 14 x 2.0:

Classification

Classification code
DIN EN 61386-22 (VDE 0605 Part 22) 3-3-2-2-2

Use according to DIN VDE 0100-520 / IEC 60364-5-52+A1:2024

Installation	Allowed	Not allowed
In the building		
Unprotected installation (on plaster)	x	
Underground installation (screed)	x	
Laid in concrete	x	
Laid in hollow wall / wood (flammable materials)	x	
Laid in plaster	x	
Laid in structural cavities	x	
Laid in suspended ceilings	x	
Ceiling installation (installation distance < 0.80 m)	x	

If fasteners are used, articles from renowned manufacturers should be used. These should correspond to the standard DIN EN 61914 (cable holder for electrical installation).

Based on DIN VDE 0100-520 and DIN VDE 0298, the maximum distances should be selected as follows, however, the specified distances of the fastener manufacturers must also be observed:

Maximum distance between the fasteners:

Outside diameter of the lines in mm	Maximum distance in mm	
	Horizontal	Vertical
$D \leq 9$	250	400
$9 < D \leq 15$	300	400
$15 < D \leq 20$	350	450
$20 < D \leq 40$	400	550

Samples of common fasteners.

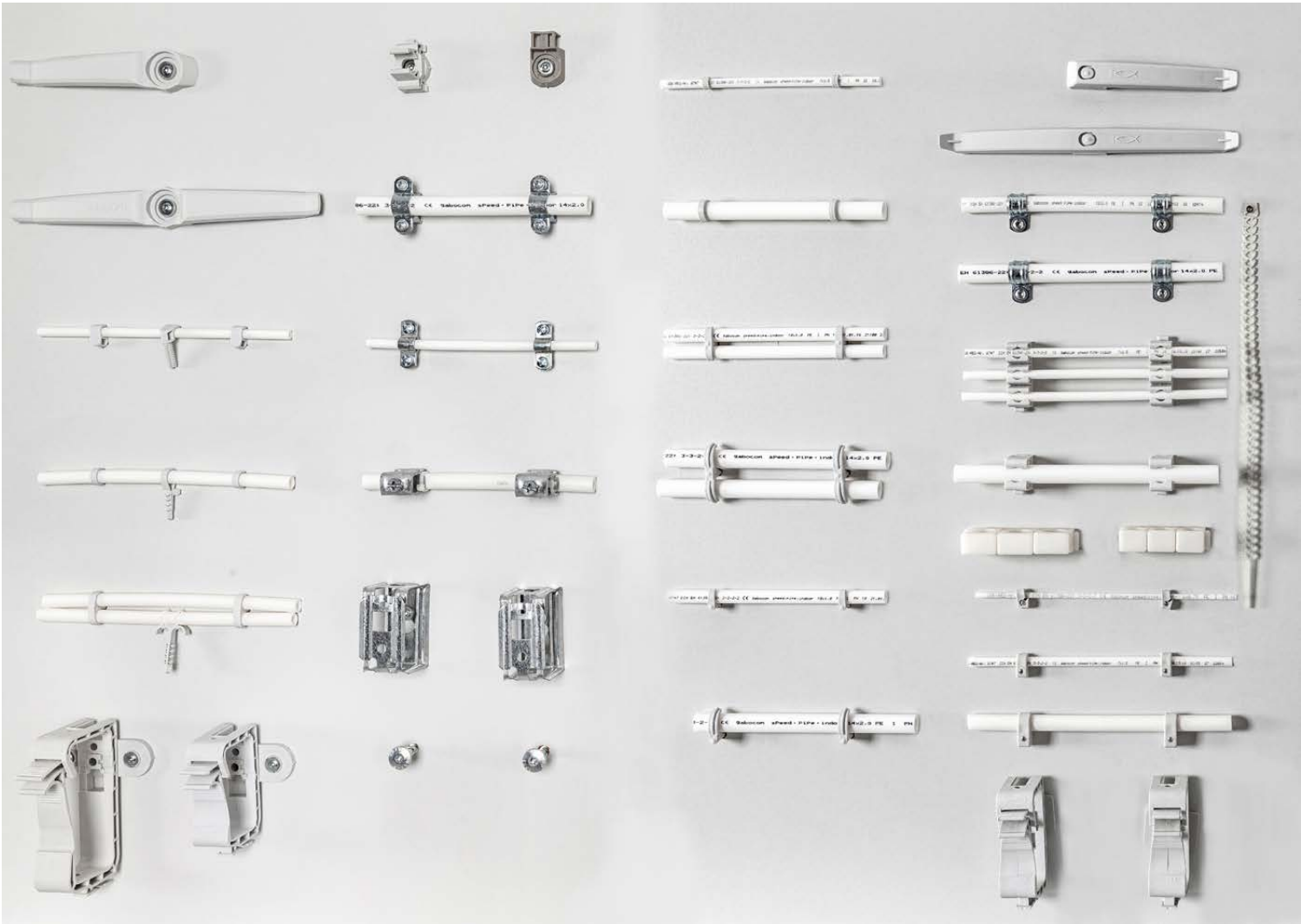

3.3 Bending radius.

The minimum bending radius for speed•pipe® indoor is 10 x the outer diameter, e. g. speed•pipe® indoor 7 x 1.5 = 70 mm minimum bending radius.

Note In a bending radius, connection sleeves must be avoided, as these can lead to the stop of a blow-in process, due to the inner edge of the open center stop.

- Recommendation**
- Always use the largest possible bending radius, as the best possible blow-in performance is to be expected.
 - Minimize the number of bending radii.

3.4 Tensile forces.

Max. recommended tensile force and tensile load of the speed•pipe® indoor in N (at 20 °C):

Term	Max. rec. tensile force	Tensile load
speed•pipe® indoor 5 × 0,75	40	100
speed•pipe® indoor 7 × 1,5	200	400
speed•pipe® indoor 10 × 1,0	200	400
speed•pipe® indoor 10 × 2,0	250	650
speed•pipe® indoor 12 × 2,0	300	900
speed•pipe® indoor 14 × 2,0	350	1100

3.5 Cutting speed•pipe® indoor.

For cutting the speed•pipe® indoor do not use a cutting tool such as a saw.

Cutting the speed•pipe® indoor for the connection with the connector (DSM indoor) must be done by means of a straight, right-angled cut to the pipe axis.

A cut-off speed•pipe® indoor, which is not subsequently connected to the DSM indoor connector, must be immediately closed against contamination and water penetration with the corresponding EZA-t or ES indoor. Please refer to the mounting instructions for the assembly of the connector.

Recommendation Separate speed•pipe® indoor with a speed•pipe® cutter.



4. Firewall.

Generally at the choice of the type of firewall please consider that the use of “pliable electrical installation pipes according to DIN EN 61386-22” or the direct use of speed-pipe® indoor must be permitted in the respective ABG (General Type Approval) or ETA (European Technical Assessment). Furthermore in the ABZ / ETA the compliance of the pipe material (synthetic / plastic) and the permitted pipe dimension must be observed.

For detailed information about the range of applications of the single firewalls, for example the possibility of the performance with bundled speed-pipe® indoor please contact the respective manufacturer of the firewall, your expert for fire protection or your technical expert.

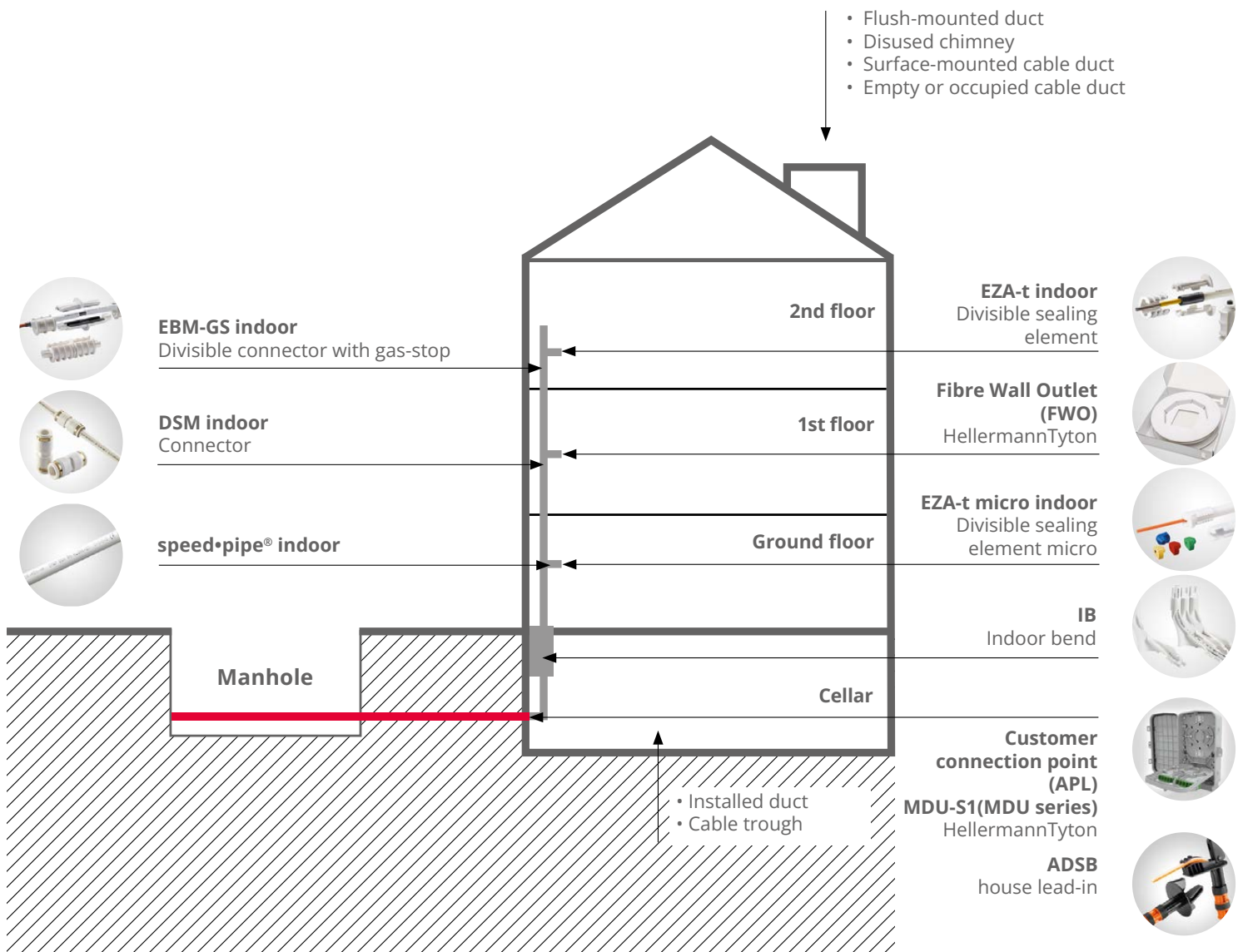

5. Blowing in micro cables / mini cables / bundle fibres

Ideal blowing in values are achieved at a temperature range of 5 to 20 °C.
The cable may not be exposed to direct sunlight. It is also helpful to use tested lubricants recommended by specialized companies.

5.1 Dependence of the blowing in lengths to be achieved on several factors.

The blowing in lengths to be achieved depend on several factors:

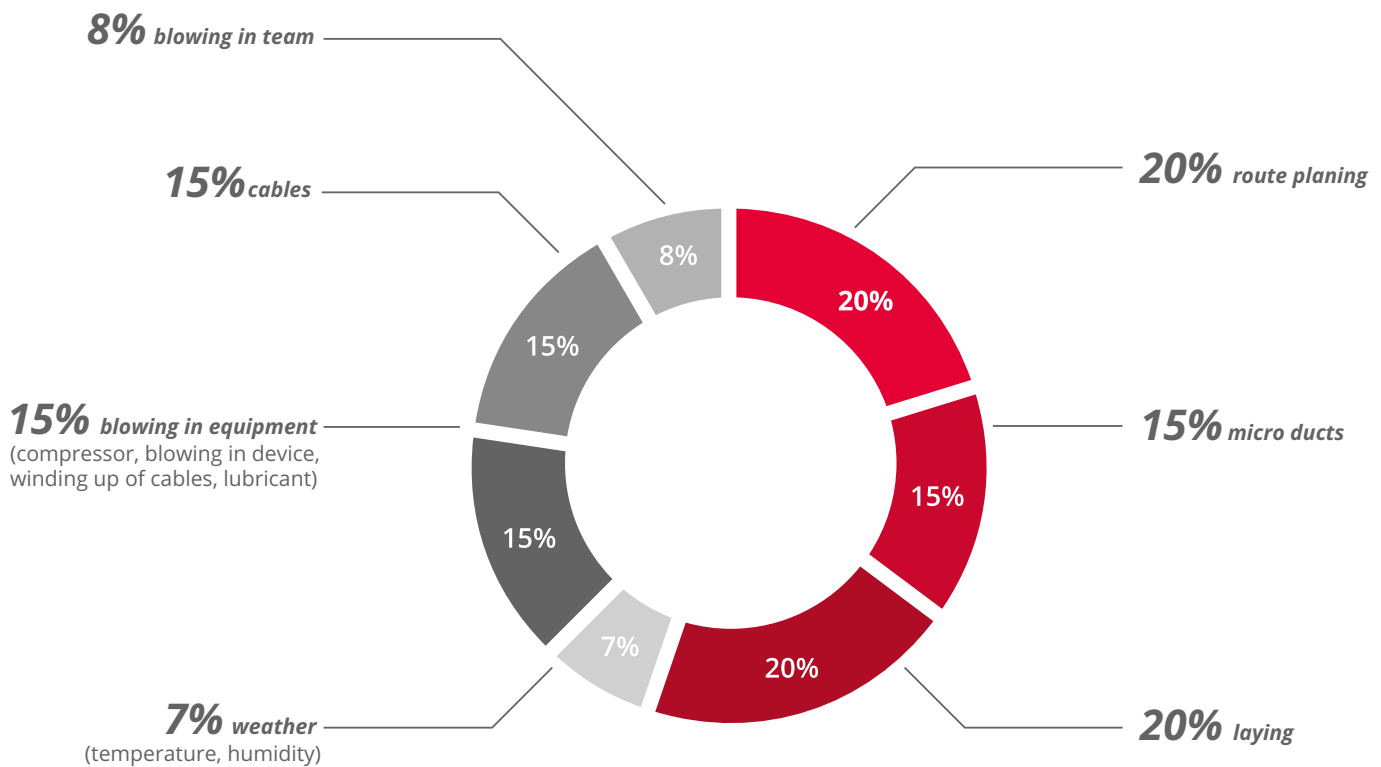

5.2 Reference values for blowing in.

The following values serve as a guideline as to which combinations of speed-pipe® indoor and fibre optic cables have already been tested in-house.

The „Indoor“ test track measures 150 m in length and includes 30 x 90 ° bends, as well as a height offset which simulates four 45 ° arches.

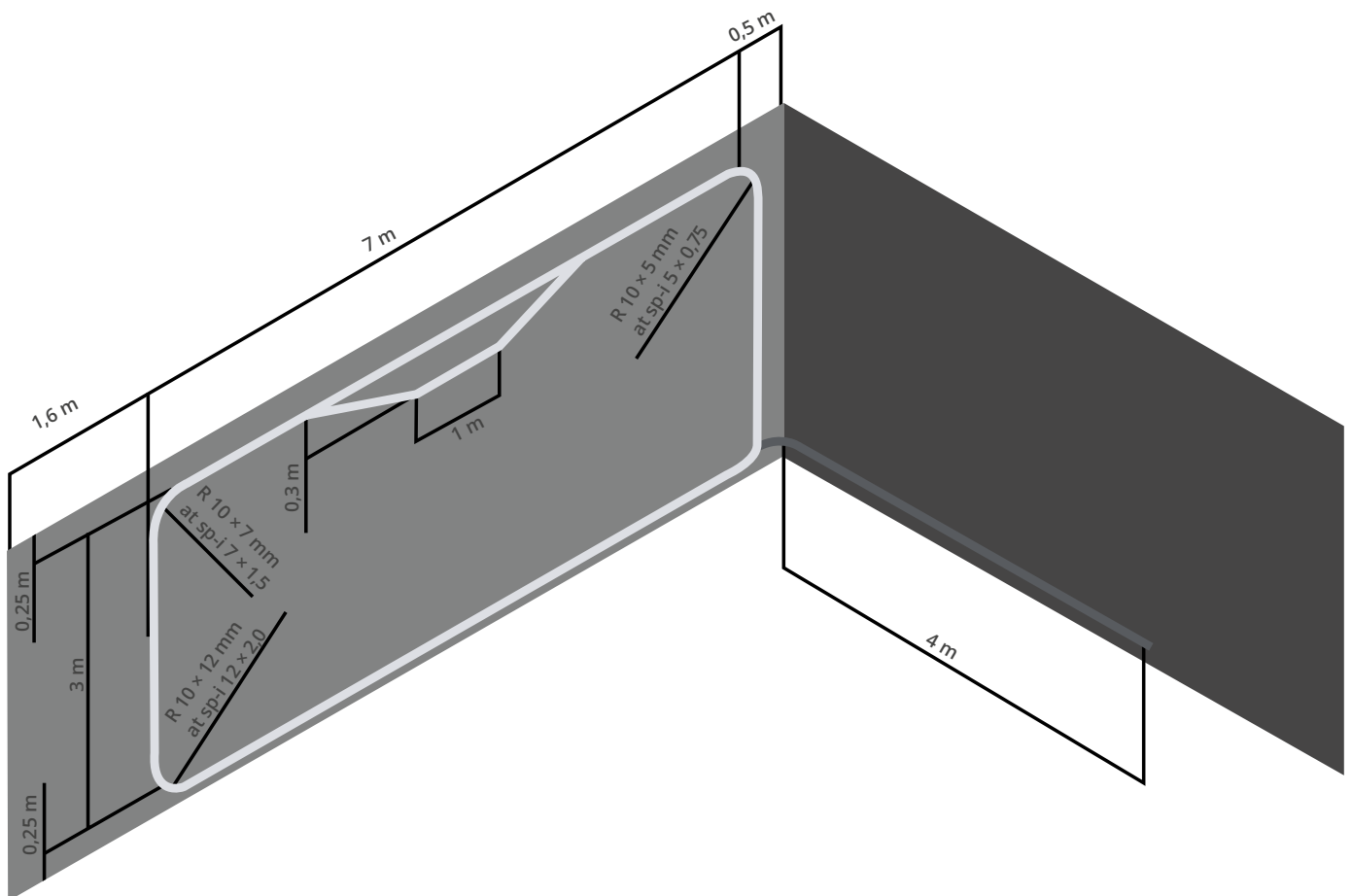

Outer diameter fibre optic cable	speed-pipe® indoor 5 x 0,75	speed-pipe® indoor 7 x 1,5	speed-pipe® indoor 12 x 2,0
Ø 1,2 mm	✓		
Ø 2,2 mm		✓	
Ø 2,4 mm		✓	
Ø 2,5 mm		✓	
Ø 2,6 mm		✓	
Ø 4,5 mm			✓
Ø 6,0 mm			✓
Ø 6,3 mm			✓

The test track „Outdoor“ for the tests measures 1250 m length and includes four 90 ° arches with $R = 2.5$ m, as well as eight 180 ° arches with $R = 7.5$ m.

TEST TERRAIN GABOCOM

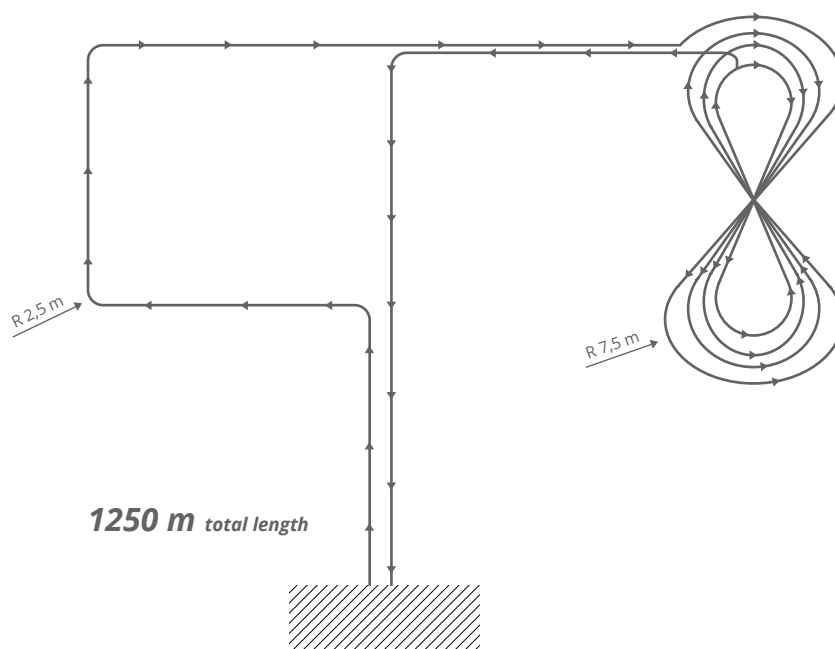

Outer diameter fibre optic cable	speed•pipe® indoor 10 x 1.0	speed•pipe® indoor 12 x 2,0
Ø 6,3 mm	✓	✓

RULES FOR THE ASSIGNMENT OF SPEED•PIPE® INDOOR IN BUILDINGS.

The installation of speed•pipe® indoor in buildings generally is subject to different rules and parameters than in the outdoor area. The adaptation to the local laying paths requires frequent bends of speed•pipe® indoor. These pipe bends require particular attention with regard to the bending radius, which should not fall below a radius of $10 \times$ of the pipe diameter in the case of free bending (no bending control element).

This ensures that the ovality of the speed•pipe® indoor in the bending area reduces the free internal diameter only within the limits specified.

5.3 Optimum blowing in lengths of micro cables / mini cables / bundle fibres.

Requirements:

- The cable diameter should be within the specified diameter ranges (see table):

speed-pipe® indoor	min. cable diameter	recommended cable diameter	max. cable diameter*
5 × 0,75	0,8 mm	1,8 mm	2,0 mm
7 × 1,5	1,0 mm	2,3 mm	2,7 mm
10 × 1,0	2,5 mm	6,2 mm	6,5 mm
10 × 2,0	1,8 mm	4,0 mm	4,6 mm
12 × 2,0	3,0 mm	6,2 mm	6,8 mm
14 × 2,0	3,0 mm	8,0 mm	8,7 mm

*inclusive tolerances

- The cable diameter has a considerable influence on the blowing in length.
- Because of the various influencing factors during the installation of speed-pipe® indoor in buildings, the different cable constructions and the various methods of introducing the cables into the pipes, the following rules should be taken into account when planning pipe systems for fibre optic networks in buildings:
 - In the interior the cables should have a preferably small diameter.
 - The central support elements of the cables should have a preferably small diameter, to allow a greater flexibility.
 - The routing of several cables with a lower number of fibres is preferable.
- When selecting the indoor cables take care that the cable has a longitudinal stiffness which can transmit the axial forces of the slide-in unit well. If the cable has a central support element, this is to be suitably made flexible on the first 50 mm (e. g. breaking the fibre fabric).
- The cable diameter should be even and should not fluctuate by more than 0.3 mm.
- The cable jacket should be as smooth as possible.
- The outer surface of the cable should be dry and clean and should not exceed a temperature of 25 °C (ideally 15 °C).
- Ideally the cable is optimized for speed-pipe® indoor and certified on a test track.
- The cable should not show any lateral run-out.

5.4 Optimum blowing in micro cables / mini cables / bundle fibres.

- The coil of the cable must be easily rotatable.
- Ensure that the coil can be braked immediately in case of an unexpected stop.
- Ensure the cable is clean.
- Clean the speed•pipe® indoor (inside) with a clean cylindrical sponge.
- Use a suitable blow-in device (for example, Vetter).
- Use a compressor with a strong airflow, with max. pressure of 15 bar (1m³ air volume for speed•pipe® indoor to inside diameter 12 mm).
- The air from the compressor should be clean, oil-free, dried and cooled down with an aftercooler to a temperature that is 8 °C to 10 °C higher than the ambient temperature
- The maximum blowing in speed should be limited to 80 m/min.
- A cable guide head should be installed at the cable tip.

5.5 Use of lubricant.

- Use suitable lubricant (e. g. Vetter)
- Pay attention to correct dosage according to manufacturer's instructions.
- Spread the lubricant in the speed•pipe® indoor by means of a cylindrical sponge before blowing in the cable.

6. Pictures from building site.





6. Pictures from building site.







Contact.
Personal. Competent.

gabo Systemtechnik GmbH
a HellermannTyton Company
Am Schaidweg 7
94559 Niederwinkling
GERMANY

Tel. +49 9962 950-200
Fax. +49 9962 950-202

info@gabocom.com
www.gabocom.com